

Now you can safely control  
your filtering process

# SAFEsystem™

*Safety Apparatus Filter Enhancement*



*Available on  
Individual, Duplex  
or Multi-Housing  
ASME Code filter  
systems.*

**Filtration Systems™**

Division of Mechanical Mfg. Corporation

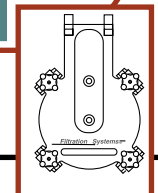

TM

# Is employee safety a primary concern?

Promoting safety in the workplace is every employer's responsibility, providing safer filtration equipment is ours!

You can now reduce employee exposure to potentially hazardous filtering processes with the unique and exclusive **SAFesystem™** option. This equipment upgrade prevents the filter vessel from being accidentally opened while in service. In addition, the vessel cannot be pressurized until both the filter lid and Safety Shield are closed.



The **SAFesystem** is designed to assure user compliance as a safeguard against misuse or improper operation of our filtration equipment. Our patented equipment option is available when ordering any **Filtration Systems** ASME Code individual, duplex or multi-housing system.

## Features

### Protective Safety Shield with Viewing Window and Retractable Locking Pin

The stainless steel Safety Shield covers the entire lid and is hinged to the body of each filter vessel. This design feature protects operators from side spray, should they accidentally pressurize the filter system without properly securing the lid of the vessel. The Safety Shield has a polycarbonate viewing window for monitoring the upstream pressure and temperature gauges. A retractable locking pin mechanism prevents unintentional closure of both the Safety Shield and filter vessel lid.

### Filtration Systems Ball Valves

All filter vessels with the **SAFesystem** upgrade utilize two stainless steel, full-port, three-piece ball valves with Teflon seats and gaskets. Functioning as shut-off valves, they isolate the housing from the filtering process. Individually valved vessels on duplex or multi-housing systems operate independently, allowing continuous service during media removal and replacement.

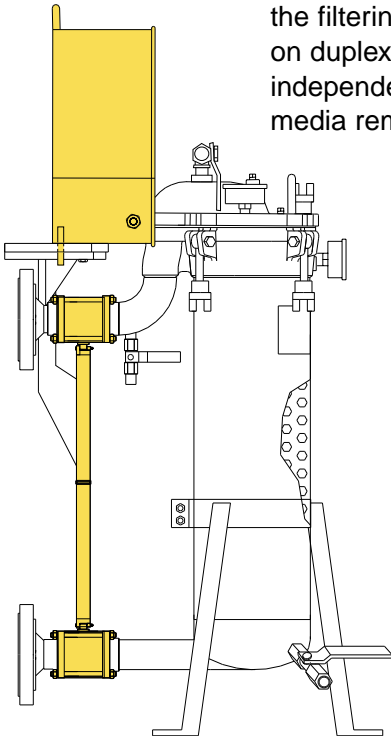

### Dual-Valve Linkage Mechanism

The dual-valve linkage mechanism coordinates with the Safety Shield and prevents the vessel from inadvertently being opened until the inlet and outlet valves are closed, isolating the vessel from the fluid stream. Operated by a 90-degree turn of the handle, this mechanism opens and closes both the inlet and outlet valves simultaneously. The inlet and outlet valves feeding the vessel cannot be reopened until the lid and Safety Shield are returned to the closed position.



# SAFEsystem™ Features

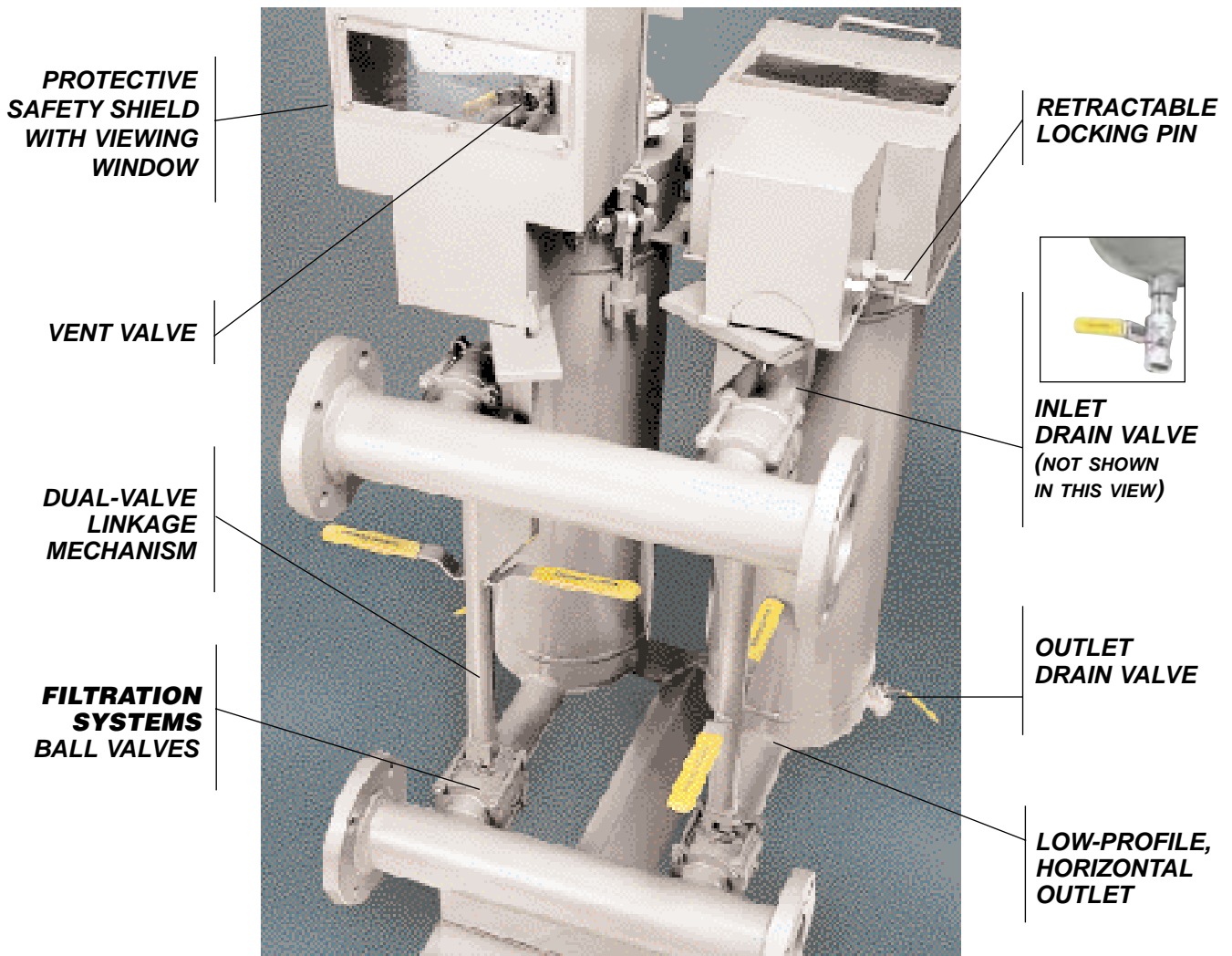

When in the closed position, the dual-valve linkage ensures that the vessel is “off-line” and safe to open. If either the vessel lid or Safety Shield is left open, the filter will not operate.

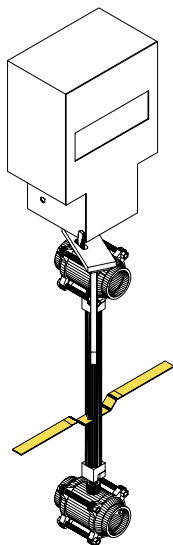

*Inlet and Outlet Ball Valves shown in closed position, illustrating the vessel is “off-line”. Safety Shield is open, allowing access to the lid of the housing for media change.*

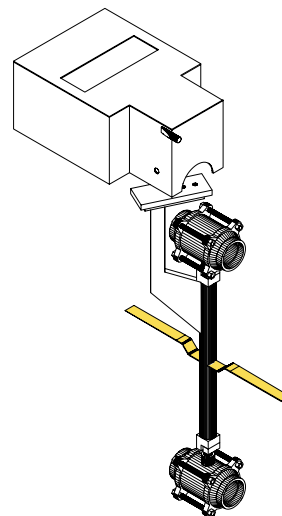

*Inlet and Outlet Ball Valves shown in open position, illustrating the vessel is “on-line”. Vessel is now pressurized and operational.*

Note: To ensure proper operation, the **SAFEsystem** upgrade is available on new equipment only. Existing housings in the field cannot be retrofitted with this upgrade.

## **SAFEsystem Features and Equipment** (stainless steel)

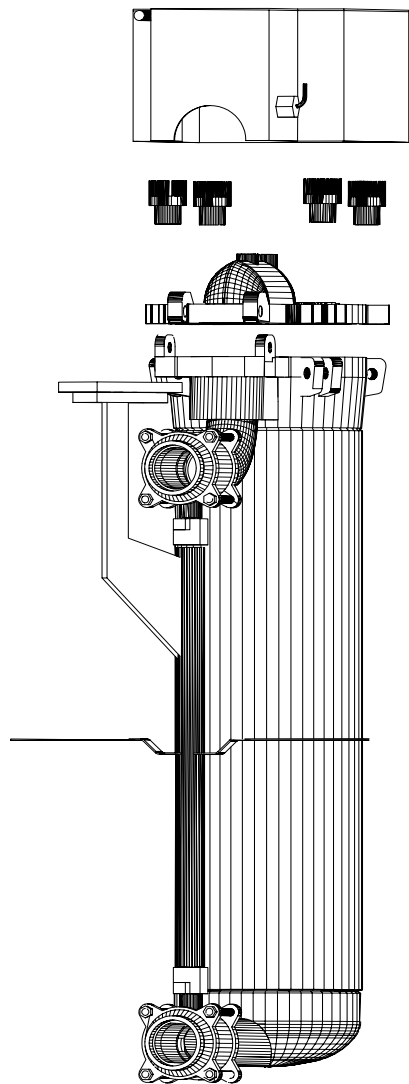

- Protective Safety Shield with Viewing Window and Retractable Locking Pin
- **Filtration Systems** Ball Valves, two per vessel
- Dual-Valve Linkage Mechanism
- Low-Profile Horizontal Outlet
- Proximity Switch Bracket
- Thermometer, one per vessel
- 1/4" Ball Valve, one per vessel (Lid Vent Port)
- 1/4" Ball Valve, one per vessel (Inlet Drain Port)
- 3/4" Ball Valve, one per vessel (Outlet Drain Port)
- Pressure Gauges, two per vessel (Upstream/Downstream)
- **SAFEsystem** Instruction Guide

### **Retractable Locking Pin Mechanism**

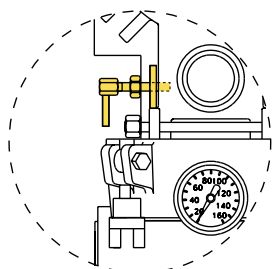

**Front View A**

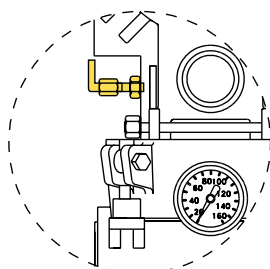

**Front View B**

**A)** Close-up view showing the retractable Locking Pin Mechanism in the locked position, preventing accidental closure of the Safety Shield and the Vessel Lid.

**B)** Close-up view showing the spring-loaded, Locking Pin Mechanism released, allowing closure of the Safety Shield and/or the Vessel Lid.

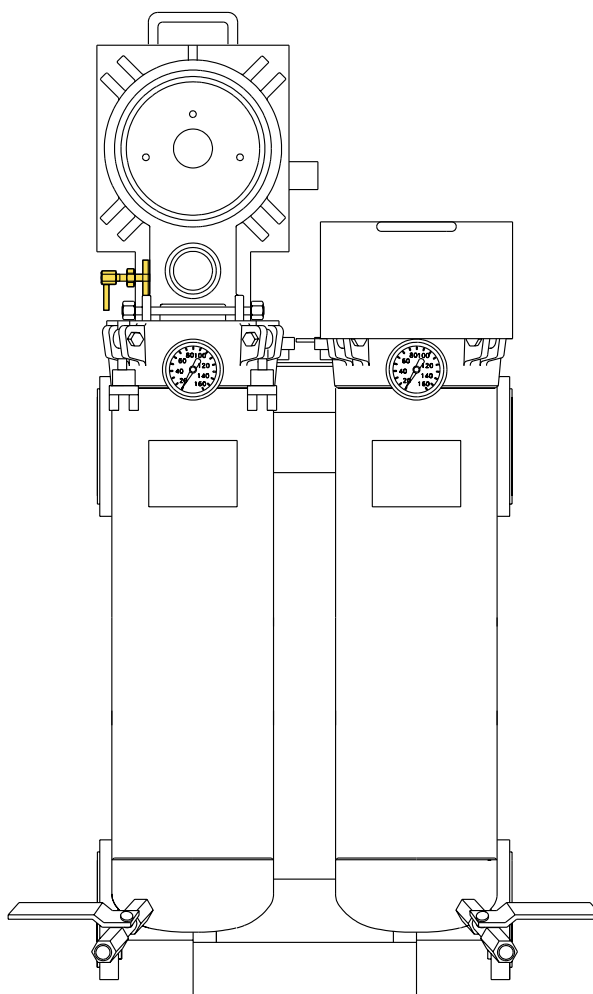

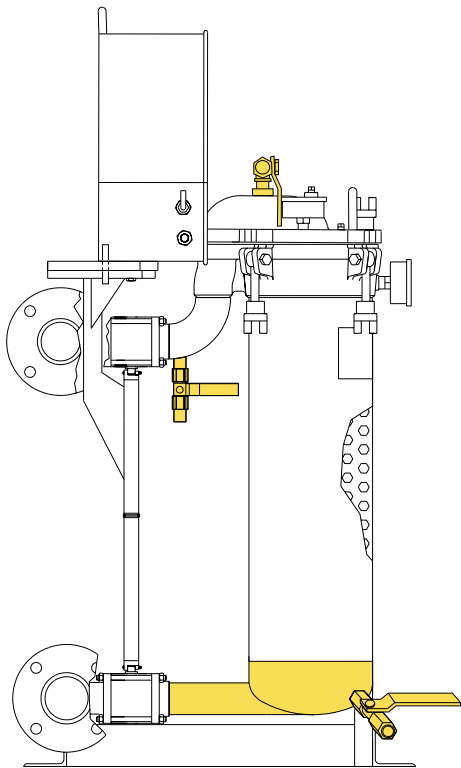

## Auxiliary Valve Ports

### Vent Valve

The 1/4" vent valve serves as a vacuum breaker, promoting faster gravity drainage when used in conjunction with the inlet and outlet drain valves.

### Inlet Drain Valve

The 1/4" upstream drain valve is located on the inlet elbow. After taking the vessel off-line, isolating it from the fluid stream, any unfiltered residual liquid may be drained from this port. During operation the upstream drain can also be used for sampling pre-filtered liquid.

### Outlet Drain Valve

The 3/4" outlet drain valve, located at the base of the filter, allows users to collect any filtered liquid remaining in the vessel after it is taken off-line and prior to opening the housing for media replacement. During operation the downstream drain can also be used for sampling filtered liquid.

## Low-Profile Horizontal Outlet

The low-profile outlet is a one-piece investment casting exclusive to the **Filtration Systems** product line and is an integral part of the **SAFEsystem**. This design feature lowers the working height of our equipment, eliminating the need for a step stool or ladder when changing filter bags. Lower working height means easier filter bag change-out for operators. As a result, ergonomic-related injuries and accidental spills may be reduced.

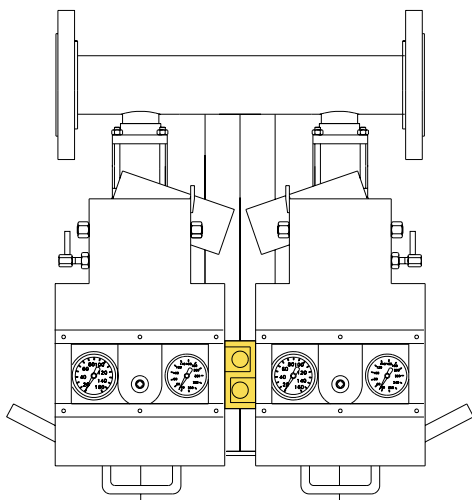

## Proximity Switch Bracket

All **SAFEsystem** vessels include a bracket and contact for installation of a proximity switch (user furnished) to deactivate the pump. The use of a proximity switch can prevent a pump from being turned on accidentally.



# Safety Information

## Checklist for Safe Operation of Pressurized Liquid Filters

**Filtration Systems** filter vessels are designed to filter liquids under pressure, in accordance with the temperature and pressure restrictions stamped on the nameplate. The **SAFEsystem** upgrade does not alter the pressure and temperature specifications of our filter housings or modify standard operating procedures.

- 1) Follow the Instructions in the "Installation, Operating & Safety Manual for Liquid Filter Housings and Filter Bags". Save both the Manual and Instruction Guide for review by all personnel who use this equipment.
- 2) Wear protective garments, splash protection, eye protection and respirators, as required.
- 3) Before pressurizing a filter vessel, always make sure you have fastened the lid hardware.
- 4) "O-Rings" are subject to wear and should be checked each time the filter vessel is opened. Replacement of O-Rings should be done prior to pressurization of the filter vessel. Be certain that the O-Ring material is both chemically and thermally compatible with the liquid being filtered. Liquid compatibility includes all materials in contact with the liquid under elevated pressures and temperatures.
- 5) Always relieve pressure in and to the system before loosening the lid hardware or opening the vessel lid.
- 6) In certain operating environments, static electrical charges or sparks may cause combustion or explosion of volatile materials. Properly ground equipment as required.
- 7) Removing filter media from packaging may also produce static electrical sparks. To avoid risk of combustion or explosion, never open static packaging in or around areas containing potentially flammable or explosive materials, liquids or gases.
- 8) Dispose of filter media properly. A filter bag that has been used with a hazardous liquid may contain residual amounts of this material and should be handled with the same safeguards that would be used in handling hazardous and/or toxic material. Media should be disposed of in accordance with federal, state and/or local laws or requirements.

**Improper use of pressurized filter vessels may result in injury or property damage. Any misuse or modification to our products will void both the manufacturer's warranty as well as the ASME certification of ASME Code vessels. Safety information does not by itself eliminate any danger. Information or warnings are not a substitute for proper accident prevention measures.**

### Lethal Service

**Filtration Systems** vessels are not designed for lethal service. "Lethal Service" refers to vessels containing lethal substances, poisonous gases or liquids of such a nature that a very small amount of the gas or vapor of the liquid (mixed or unmixed) is dangerous to life when inhaled. In addition, substances of this nature that are stored under pressure, or may generate pressure if stored in a closed vessel, are considered lethal.

### Product Identification

All **Filtration Systems** filter vessels have a unique serial number that can be identified by our factory. Nameplates, specifying both the serial number and maximum allowable pressure and temperature rating are permanently affixed to all housings.

### Product Specifications

With over 30 years of industry expertise and proven performance, **Filtration Systems** offers quality products at responsible prices. We continually strive to improve our products through ongoing research and development; therefore, we reserve the right to change specifications without notice.

### Intellectual Property

As with all **Filtration Systems** patented products, the **SAFEsystem**™ offers exclusive manufacturing technology designed to complement our equipment. This company is committed to protecting its patents, trademarks, and proprietary rights from those who would wrongfully use them. The **SAFEsystem**™ is patented.

**SAFEsystem**™, **Zero-Bypass**™ and **Filtration Systems**™ are trademarks of Mechanical Mfg. Corporation. **Accufit**® and **Ultrafit**® are registered trademarks of Mechanical Mfg. Corporation, **Filtration Systems** division.

### Warranty

**Filtration Systems** warrants our products to be free from defects in workmanship for a period of one year from the date of purchase, when used in accordance with our specific guidelines. Our only obligation and a customer's remedy, subject to our inspection and evaluation, shall be to replace the product or refund the purchase price.

### Limitation of Liability

**Filtration Systems** shall not be held responsible or liable for any loss resulting from the resale, direct or indirect misuse, incidental or consequential damages, arising out of the use of this product.

Manufactured by: **Filtration Systems**™

Division of Mechanical Mfg. Corporation  
10304 N.W. 50th Street • Sunrise, FL 33351 USA  
Tel: 954-572-2700 • Fax: 954-572-3401  
<http://www.filtrationsystems.com>