

Miniature Liquid Filter Bag Housings

Over-the-Top® Design

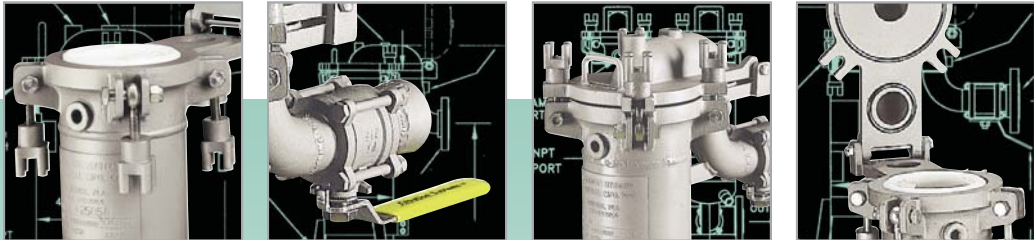

Technical Bulletin G

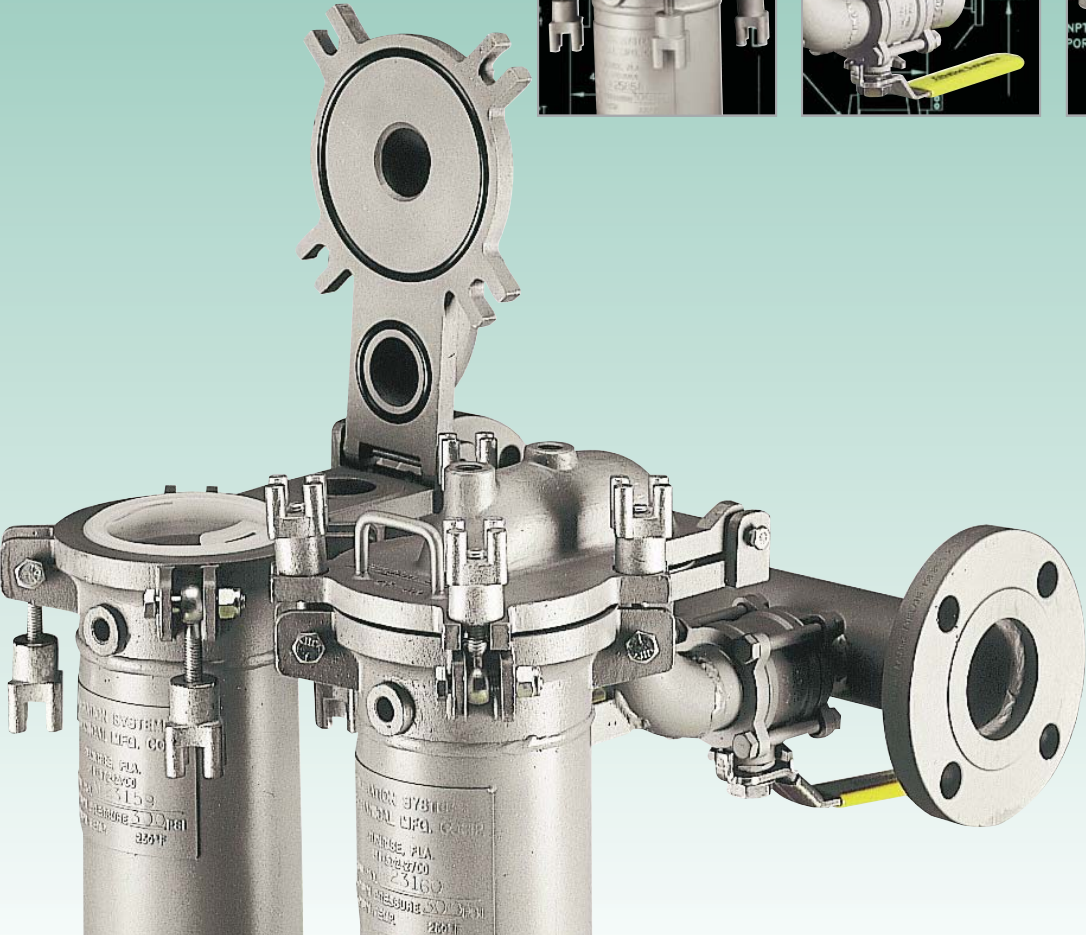

Filtration Systems

Division of Mechanical Mfg. Corporation

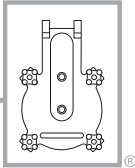

INDIVIDUAL FILTER HOUSINGS



**Model
NS-141
or
S-141**



**Model
NS-151
or
S-151**

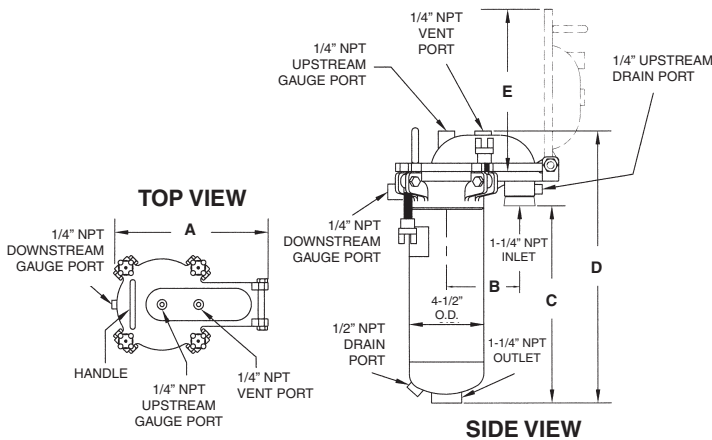

MODEL	A	B	C	D	E	WT/LBS
NS-141	9 ³ / ₄ "	4 ¹ / ₂ "	11 ³ / ₄ "	16 ³ / ₄ "	9 ¹ / ₂ "	25

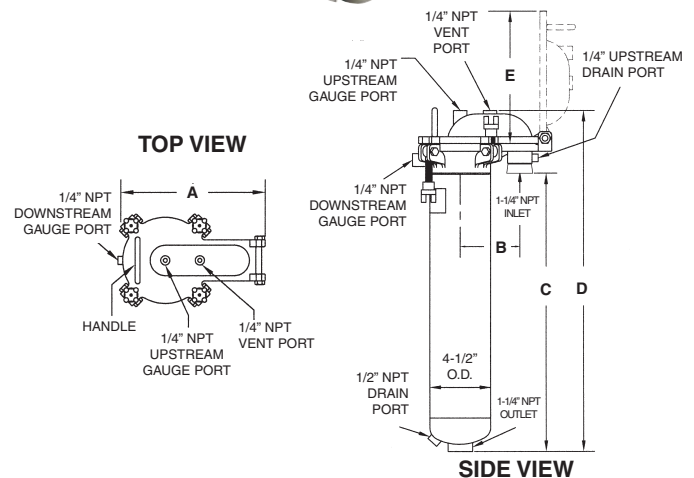

MODEL	A	B	C	D	E	WT/LBS
NS-151	9 ³ / ₄ "	4 ¹ / ₂ "	21 ³ / ₄ "	26 ³ / ₄ "	9 ¹ / ₂ "	30

Description

Miniature Liquid Filter Housings provide the ideal solution for straining and fine filtration at lower flow rates or when space is at a premium. Their compact size, low cost, and ability to accommodate a variety of filter media make Miniatures highly versatile for industrial applications. Individual, Valved-Individual, and Duplex models accommodate size #4 (4"dia. x 14"long) or #5 (4"dia. x 24"long) filter bags, cartridges, or strainer baskets.

Filtration Systems Miniature Liquid Filter Housings feature *Over-The-Top*[®] design. Compression of our *Zero-Bypass*[®] bag collar between the housing lid and the top of the support basket provides a positive 360-degree seal, preventing bypass of unfiltered liquid. Solids are trapped and collected in the bag, eliminating clean up of the vessel interior during bag change-out.

All housings are built to ASME specifications and may be ordered with an optional U-Stamp. Vessels are available in T-316 stainless steel or carbon steel, rated for 300psi @ 400°F. Alternate inlet and outlet connections may be ordered to allow the vessels to be placed directly in line with existing process piping.

Valved, Individual Housings allow liquid flow to be shut off at the unit, rather than at a distant source, saving time during media change-out.

Valved, Duplex Filter Systems allow increased flow rates by using both housings simultaneously. Two stainless steel ball valves, on the inlet and

outlet of each vessel, function as shut-off valves, isolating individual housings from the filtering process. Each vessel operates independently, allowing continuous service during media removal and replacement.

Miniature Duplex Systems are equipped with two inlet and two outlet connections. Alternate connection ports allow users the option of choosing any inlet and outlet site(s) to accommodate space and piping requirements. Unused ports are sealed with user-furnished blind flanges. Duplex Systems are available in 150 or 300psi with corresponding flanges. Filtration Systems versatile, modular design provides simplified installation, equipment expansion, and header inspection and cleaning. Systems are shipped fully assembled, built on a stable frame, and require no anchor bolts for installation.

Standard Features

Over-The-Top Design

Built to ASME Code Standards

T-316 Stainless Steel or Carbon Steel

Available in 300psi Max. Working Pressure

400°F Max. Working Temperature

Investment Cast Lid and Body

Hinged Lid with Handle, Built-in Lid Stop, and Safety Detents

Perforated, T-316 S/S Support Basket with Longitudinal Taper

Gauge Ports, Vent Ports, Drain Ports

Buna-N O-Rings

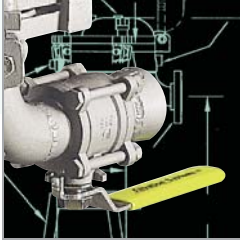

VALVED, INDIVIDUAL HOUSINGS

**Model
NS-141-V
or
S-141-V**



**Model
NS-151-V
or
S-151-V**

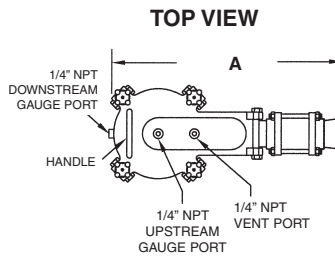
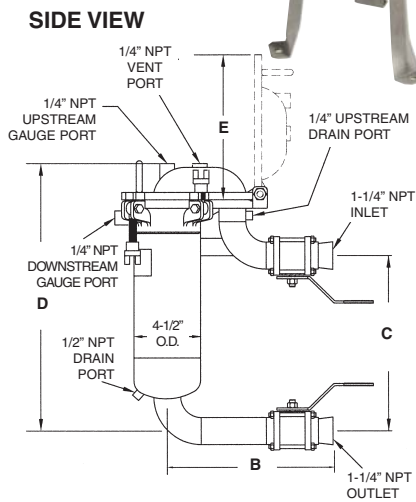

Tripod Stands Sold Separately

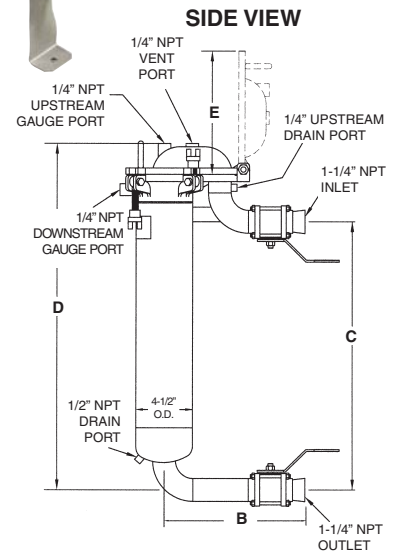

MODEL	A	B	C	D	E	WT/LBS
NS-141-V	14 ¹ / ₄ "	11 ¹ / ₈ "	11 ¹ / ₂ "	18 ¹ / ₂ "	9 ⁵ / ₁₆ "	30

MODEL	A	B	C	D	E	WT/LBS
NS-151-V	14 ¹ / ₄ "	11 ¹ / ₈ "	21 ³ / ₄ "	28 ⁵ / ₈ "	9 ⁵ / ₁₆ "	40

MODEL NUMBER CODING SYSTEM

MATERIAL OF CONSTRUCTION

NS = T-316 S/S, Industrial Grade
S = T-316 S/S, ASME Code (U-Stamp)
NC = Carbon Steel, Industrial Grade
C = Carbon Steel, ASME Code (U-Stamp)

VALVED HOUSING OR SYSTEM

Filtration Systems Inlet & Outlet
 Isolation Valves, T-316 S/S
V = Ball Valves, 3-Piece, Full-Port
SV = Sanitary Butterfly Valve

MODIFIED

Modified Equipment,
 as per quote or requirement

NS - 242 - V - 300 - M

**NUMBER OF
FILTER MODULES**

**HOUSING SIZE/
FILTER BAG SIZE**
 4 = #4 Size (4" Dia. x 14" Long)
 5 = #5 Size (4" Dia. x 24" Long)

**INLET & OUTLET
CONNECTION SIZE**
 1 = 1-1/4" Connection
 2 = 2" Connection

300psi PRESSURE RATING

R/F ANSI Flanges,
 NPT, or Sanitary
 Connections available



DUPLEX FILTER SYSTEMS

**Model
NS-242-V
or
S-242-V**

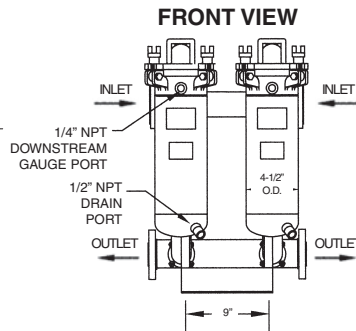
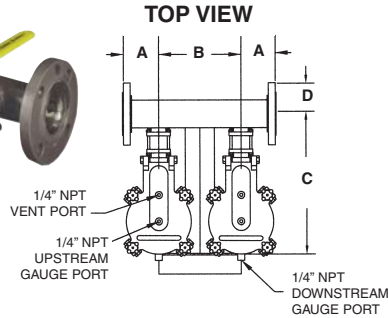
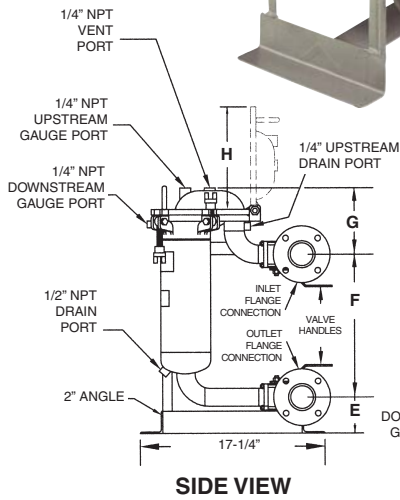

**Model
NS-252-V
or
S-252-V**

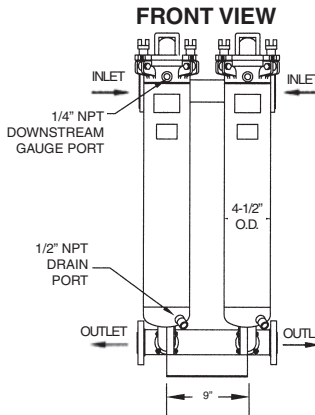
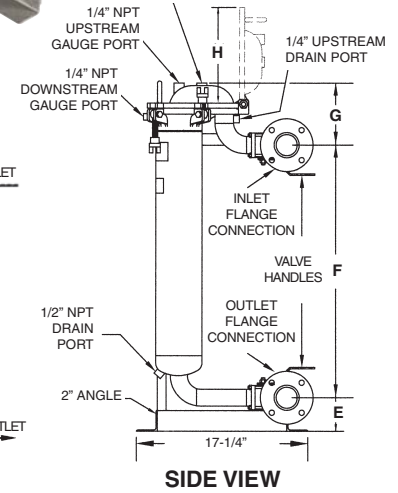

MODEL	A	B	C	D	E	F	G	H	WT/LBS
NS-242-V	4"	8"	13 ³ / ₄ "	3"	3 ¹ / ₄ "	12 ¹ / ₄ "	5 ¹ / ₂ "	9 ¹ / ₂ "	105

MODEL	A	B	C	D	E	F	G	H	WT/LBS
NS-252-V	4"	8"	13 ³ / ₄ "	3"	3 ¹ / ₄ "	22 ¹ / ₄ "	5 ¹ / ₂ "	9 ¹ / ₂ "	120



PIPE-END FILTER SYSTEM

The **Pipe-End Filter System** is ideally suited for various types of liquid straining and filtering applications typically found in industry. Examples of its versatility include:

1. Permanent installation to a pipe-end for bulk loading or high-volume tank filling.
2. Connection to an industrial hose for filtering liquid deliveries to a production/distribution facility. The filter bag may be removed and easily inspected to evaluate the purity of a delivery.

The Pipe-End Filter System provides effective, low-cost filtration without the nuisance and hazard of spillage. A shut-off valve isolates the filter during bag change-out, minimizing waste and employee exposure. Handles provide easy removal of the basket and filter bag. The quick-opening, cam & groove mechanism is easier to use than clamp-style, unsupported devices.

Constructed of T-316 stainless steel, the system includes a *Filtration Systems* Ball Valve and a Perforated Support Basket for #5 size filter bags (4" dia. x 24" long). Perforated Strainers, Micron-Lined Baskets, Cartridge Chambers, and Canister Baskets for activated carbon can also be used with the Pipe End Filter System. The standard connection is 1/4" NPT and may be modified to fit larger diameter pipes or hoses (up to 2"). It is suitable for flow rates up to 50gpm.



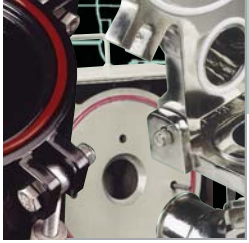

AVAILABLE OPTIONS



Interior Polished Finishes:

Interior Polished Finishes for beverage, pharmaceutical, dairy, and other critical applications.



Perforated Strainers and Lined Baskets:

Heavy-duty perforated baskets convert filter vessels into high-capacity liquid strainers. Micron Lined Baskets and Cartridge Chambers are also available.



HALAR® Lining:

HALAR Fluoropolymer Lining offers a broad range of chemical resistance properties, a seamless filtering environment, and a safe alternative to plastic housings.

- Modified Connections: Flanged, Threaded, or Sanitary
- Stainless Steel Hardware Upgrade
- Adjustable Tripod Stands and Wall Brackets
- Interior Polished Finishes, including 3A Sanitary
- HALAR Fluoropolymer Lining
- Epoxy Coating, interior, exterior & stand
- Mesh & Micron Lined Baskets, S/S
- Perforated Strainer Baskets, S/S
- Cartridge Chambers, S/S
- Alternate Outlet Locations
- Additional Ports
- Drain Valves, Vent Valves, Pressure Gauges
- Assorted O-Ring Materials
- PED – Pressure Equipment Directive
- ASME U-Stamp

HALAR is a Registered Trademark of Solvay Solexis, Inc.

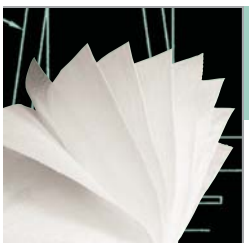

HIGH PERFORMANCE LIQUID FILTER BAGS

Filtration Systems vessels and filter media are designed to work together as a system, maximizing performance and results.

- Efficiency Ratings up to 99.98%...
provides absolute rated performance
- Fully Welded Construction...
eliminates solids bypass
- Zero-Bypass® Bag Collar...
assures an optimum compression seal
- Integrated Polymeric Support®...
provides superior mechanical strength
- Ratings from 0.2 to 800 Microns...
absolute or nominal ratings



Ultrafit® Welded and Accufit® Welded Liquid Filter Bags

STANDARD SPECIFICATIONS AND FEATURES

MINIATURE HOUSINGS	INDIVIDUAL FILTER HOUSINGS		VALVED, INDIVIDUAL HOUSINGS		VALVED, DUPLEX SYSTEMS		
	141	151	141-V	151-V	242-V	252-V	
FILTER BAG SIZE	#4 (4" dia. x 14" long)	#5 (4" dia. x 24" long)	#4 (4" dia. x 14" long)	#5 (4" dia. x 24" long)	TWO, #4 SIZE (4" dia. x 14" long)	TWO, #5 SIZE (4" dia. x 24" long)	
MAXIMUM FLOW RATE* (without Filter Media)	55 gpm @ 1.1 psid	80 gpm @ 1.5 psid	55 gpm @ 1.1 psid	80 gpm @ 1.5 psid	110 gpm @ 1.1 psid	160 gpm @ 1.5 psid	
LIQUID VOLUME (gal/water)	.75 gal	1.4 gal	1.0 gal	1.5 gal	2.25 gal	3.5 gal	
CODE STATUS	Industrial Grade or ASME Code (U-Stamp) Note: ASME Code jurisdiction ends at the Inlet and Outlet Elbow of each module						
MATERIAL OF CONSTRUCTION	T-316 S/S or Carbon Steel, Investment Cast Lid & Body						
LID CLOSURE	360° Hinged Closure with Lid Handle, Safety Detents, and Lid Stop						
MAXIMUM WORKING PRESSURE**	300psi						
MAXIMUM WORKING TEMPERATURE	400°F						
MAXIMUM SUPPORT BASKET DIFFERENTIAL OPERATING PRESSURE	100psi						
INLET & OUTLET CONNECTIONS	1-1/4" NPT				2" Flanges, 300psi, R/F, ANSI (150psi Flanges on 150psi System optional)		
BALL VALVES: 1 1/2" FULL PORT, T-316 S/S & TEFLON, 800psi	N/A	N/A	2	2	4	4	
FINISH	S/S Housings:	Blasted Finish, Interior, Exterior & Basket					
	Carbon Housings:	One Coat Shop Primer, Exterior					
HARDWARE	Plated Carbon Steel Bar Knobs & Eye Bolts						
PERFORATED SUPPORT BASKETS	T-316 S/S with Longitudinal Taper, 9/64" Perforations (1 per housing)						
GAUGE PORTS	1/4" NPT (2 per housing)						
VENT PORTS	1/4" NPT (1 per housing)						
UPSTREAM DRAIN PORT	1/4" NPT (1 per housing)						
DOWNSTREAM DRAIN PORT	1/2" NPT (1 per housing)						
O-RINGS	Buna-N, Installed						
STAND / FRAME	S/S Housings:	Tripod Stand or Bracket Sold Separately				S/S Frame	
	Carbon Housings:	Tripod Stand or Bracket Sold Separately				Carbon Steel Frame	
SHIPPING WEIGHT (LBS)	25 lbs	30 lbs	30 lbs	40 lbs	105 lbs	120 lbs	

* Flow Rates are based on water in a housing without filter media. Actual flow rates are determined by the specific filter media selected, as well as the characteristics of the application.

** Units are Hydrostatically Tested to 1-1/2 times the Maximum Working Pressure.



ADJUSTABLE TRIPOD STANDS and WALL BRACKETS

Adjustable Tripod Stands allow the user to raise and lower a filter vessel, as required. Wall Brackets allow Miniature Housings to be mounted to a wall. Stands and Brackets are available in stainless or carbon steel for #4 or #5 size filter housings. Sold separately.



Product Identification: All *Filtration Systems* filter vessels have a unique serial number that can be identified by our factory. Nameplates, specifying both the serial number and maximum allowable pressure and temperature ratings, are permanently affixed to all housings.

Product Specifications: With over 30 years of industry expertise and proven performance, *Filtration Systems* offers quality products at responsible prices. We continually strive to improve our products through ongoing research and development; therefore, we reserve the right to change specifications without notice.

Warranty: *Filtration Systems* warrants our products to be free from defects in workmanship for a period of one year from the date of purchase, when used in accordance with our specific guidelines. Our only obligation and a customer's remedy, subject to our inspection and evaluation, shall be to replace the product or refund the purchase price.

Limitation of Liability: *Filtration Systems* shall not be held responsible or liable for any loss resulting from the resale, direct or indirect misuse, incidental or consequential damages, arising out of the use of this product.

Filtration Systems™

Division of Mechanical Mfg. Corporation
10304 N.W. 50th Street • Sunrise, FL 33351 USA
Tel: 954-572-2700 • Fax: 954-572-3401
www.filtrationsystems.com

ISO 9001:2008 Certified