

# ASME U-Stamp Liquid Filter Bag Housings

Over-the-Top® Design

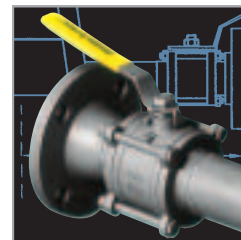

Technical Bulletin A

**Filtration Systems**

Division of Mechanical Mfg. Corporation

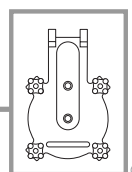

# INDIVIDUAL FILTER VESSELS



**Model S-112**



**Model S-122**

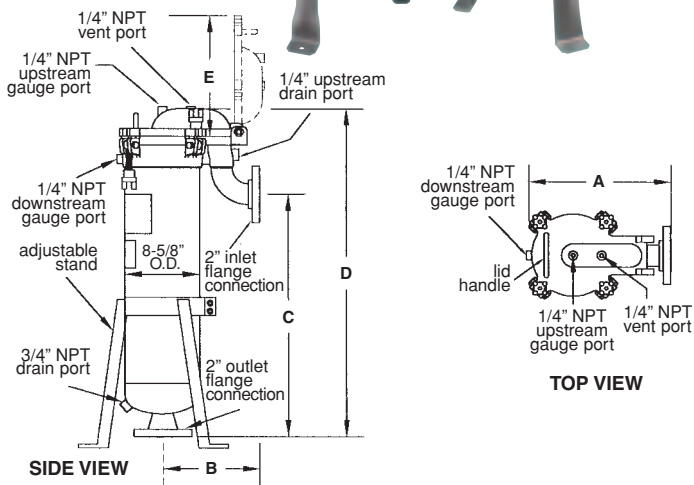

MODEL	A	B	C	D	E	WT/LBS
<b>S-112</b>	15-1/2"	10-1/2"	12"	22"	14"	110
<b>S-122</b>	15-1/2"	10-1/2"	26"	35-1/2"	14"	130

Adjustable Tripod Stand: 17" H, 12" bolt hole circle, Band: 2" wide, 8 5/8" I.D.

## Description

ASME U-Stamp Liquid Filter Housings meet the requirements of Section VIII, Division 1, and provide the ideal solution for fine filtration. *Filtration Systems* vessels feature *Over-The-Top*<sup>®</sup> design. Compression of our *Zero-Bypass*<sup>®</sup> bag collar between the housing lid and the top of the support basket provides a positive 360-degree seal, preventing bypass of unfiltered liquid. Solids are trapped and collected in the bag, eliminating clean up of the vessel interior during bag change-out.

Filter housings accommodate a variety of filter media, making them highly versatile for industrial, pharmaceutical, water, beverage, and other process applications. Individual, Valved Individual, and Multi-Housing Systems accommodate size #1 (7" dia. x 16" long) or #2 (7" dia. x 33" long) filter bags, cartridges, or strainer baskets.

Vessels are T-316 stainless steel or carbon steel, 150 or 300psi, valved or non-valved. Alternate inlet and outlet connections may be ordered, allowing the vessels to be placed directly in line with existing process piping.

**Valved, Individual Housings** allow liquid flow to be shut off at the unit, rather than at a distant source, saving time during media change-out. A Low-Profile Horizontal Outlet is a standard feature of Valved, Individual Housings.

**Multi-Housing Filter Systems** are available with 2 to 8 modules, providing increased flow rate capacity by using multiple housings simultaneously. Valved versions have stainless steel ball valves on the

# VALVED, INDIVIDUAL HOUSINGS

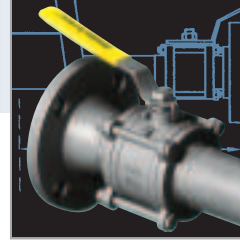

**Model S-122-LP-V**

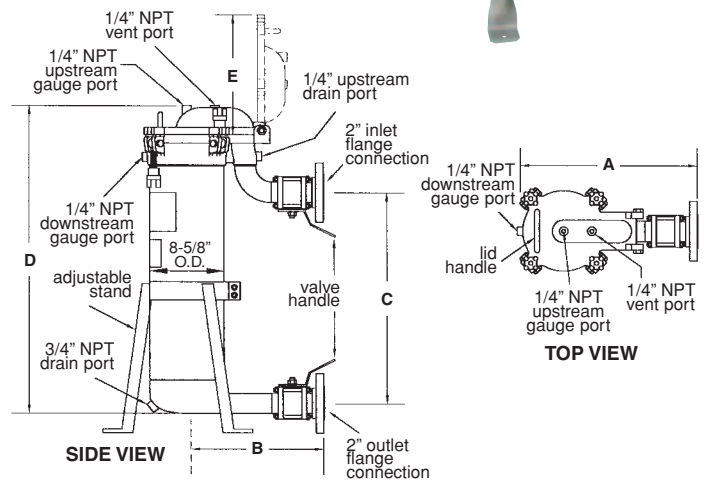

MODEL	A	B	C	D	E	WT/LBS
<b>S-122-LP-V</b>	21-7/8"	17-1/4"	22-3/4"	33-1/2"	14"	140

Adjustable Tripod Stand: 17" H, 12" bolt hole circle, Band: 2" wide, 8 5/8" I.D.

inlet and outlet of each vessel. Functioning as shut-off valves, they isolate individual housings from the filtering process, allowing continuous service of the remaining housings during media removal and replacement.

All Multi-Housing Systems are equipped with two inlet and two outlet connections. Alternate connection ports allow users the option of choosing any inlet and outlet site(s) to accommodate space and piping requirements. Unused ports are sealed with user-furnished blind flanges. *Filtration Systems* versatile, modular design provides simplified installation, equipment expansion, and header inspection and cleaning. Systems are built on a stable frame, shipped fully assembled, and require no anchor bolts for installation.

## Standard Features

### Over-The-Top Design

ASME U Stamp, Section VIII, Div. 1

Available in 150psi or 300psi maximum working pressure

Investment Cast Lid and Body

Hinged Lid with Handle, Built-in Lid Stop, and Safety Detents

Perforated T-316 S/S Support Basket with Longitudinal Taper

Gauge Ports, Vent Ports, Drain Ports

Buna-N O-Rings

Adjustable Tripod Stand, or Frame

# MULTI-HOUSING FILTER SYSTEMS



**Model S-223-V**

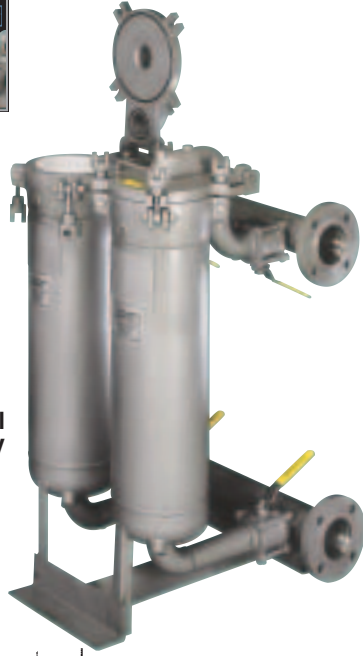

**Model S-424-V**

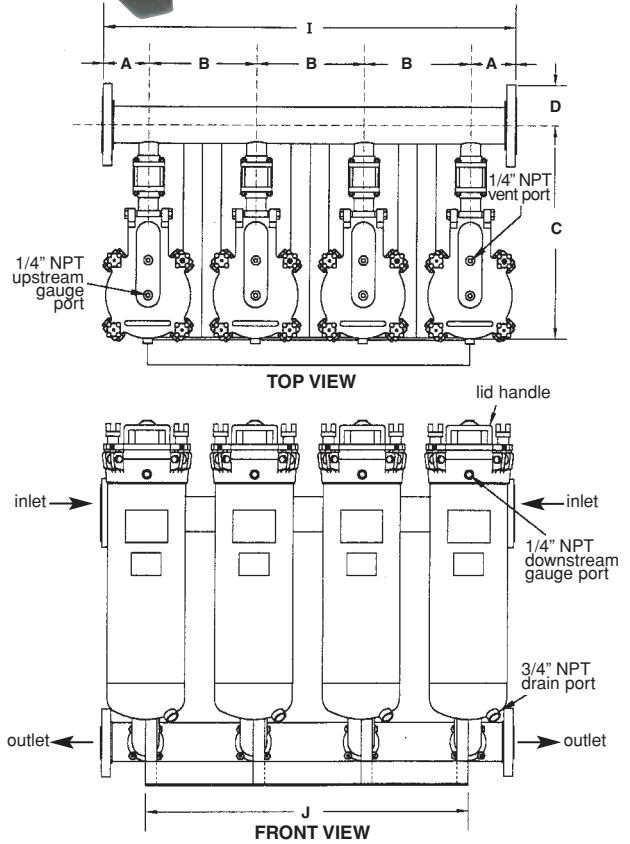
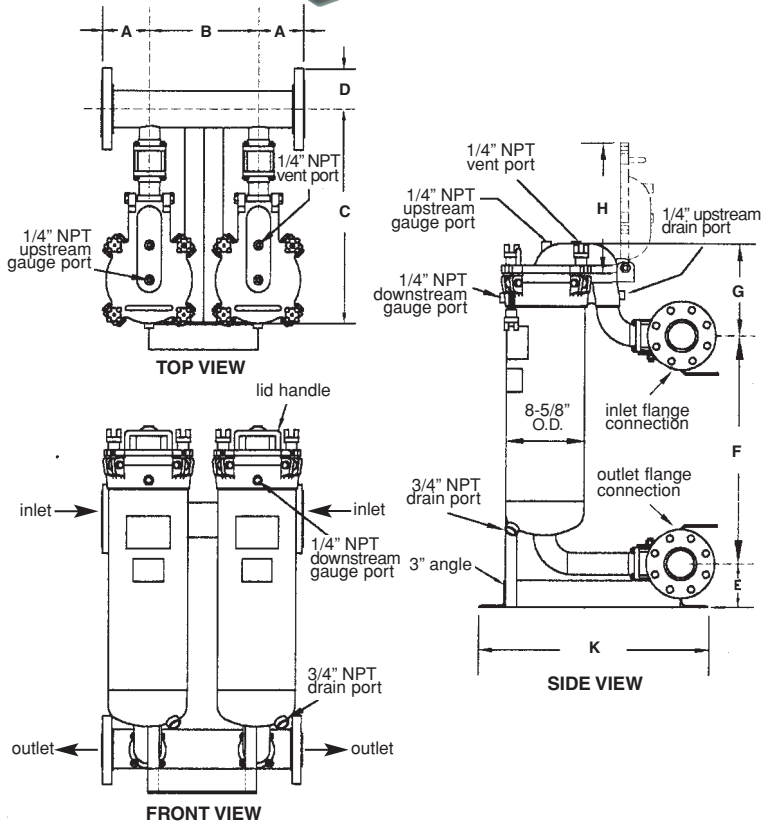
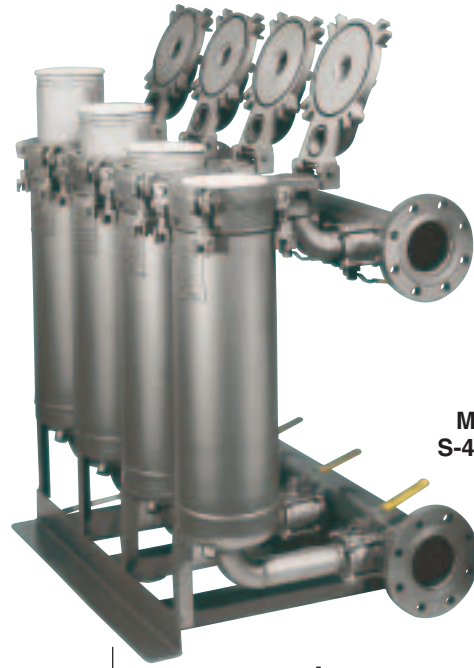

MODEL	NO. OF HOUSINGS	FLANGE SIZE (INCHES)	*MAXIMUM FLOW RATE (GPM) @ 2.2psid	LIQUID VOLUME (gal/water)	2 TO 12 MODULES AVAILABLE ALL DIMENSIONS ARE IN INCHES											SHIPPING WEIGHT (LBS)
					A	B	C **	D	E	F	G	H	I	J	K **	
-223-V	2	3	440	15.5	5	12	21	3 3/4	4 3/4	26 1/4	9 1/2	14	22	13	27	295
-324-V	3	4	660	24.4	5	12	21 3/4	4 1/2	5 1/4	26 1/4	9 1/2	14	34	25	27 1/2	435
-424-V	4	4	880	32.5	5	12	21 3/4	4 1/2	5 1/4	26 1/4	9 1/2	14	46	37	27 1/2	575
-526-V	5	6	1100	47.4	5	12	22 3/4	5 1/2	6 1/4	26 1/4	9 1/2	14	58	49	28 1/2	715
-626-V	6	6	1320	56.9	5	12	22 3/4	5 1/2	6 1/4	26 1/4	9 1/2	14	70	61	28 1/2	855
-726-V	7	6	1540	66.3	5	12	22 3/4	5 1/2	6 1/4	26 1/4	9 1/2	14	82	73	28 1/2	995
-826-V	8	6	1760	75.8	5	12	22 3/4	5 1/2	6 1/4	26 1/4	9 1/2	14	94	85	28 1/2	1135
-928-V	9	8	1980	113.9	5	12	23 3/4	6 3/4	7 3/4	26 1/4	9 1/2	14	106	97	29 1/2	1427
-1028-V	10	8	2200	126.6	5	12	23 3/4	6 3/4	7 3/4	26 1/4	9 1/2	14	118	109	29 1/2	1595
-1128-V	11	8	2420	139.3	5	12	23 3/4	6 3/4	7 3/4	26 1/4	9 1/2	14	130	121	29 1/2	1765
-1228-V	12	8	2640	151.9	5	12	23 3/4	6 3/4	7 3/4	26 1/4	9 1/2	14	142	133	29 1/2	1930

\*Flow Rates are based on water in a housing without filter media. Actual flow rates are determined by the specific filter media selected, as well as the characteristics of the application. \*\* For Non-Valved Systems, subtract 5".

# STANDARD SPECIFICATIONS AND FEATURES

ASME U STAMP HOUSINGS	INDIVIDUAL FILTER VESSELS		VALVED, INDIVIDUAL HOUSINGS	NON-VALVED MULTI-HOUSING SYSTEMS	VALVED MULTI-HOUSING SYSTEMS
	112	122	122-LP-V	2 - 12 Housings	2 - 12 Housings
FILTER BAG SIZE	#1 (7"dia. x 16"long)	#2 (7"dia. x 33"long)	#2 (7"dia. x 33"long)	#2 (7"dia. x 33"long)	#2 (7"dia. x 33"long)
MAXIMUM FLOW RATE* (without filter media)	110 gpm @ 1.1 psid	220 gpm @ 2.2 psid	220 gpm @ 2.2 psid	See Dimensional Chart, pg. 3	
LIQUID VOLUME (gal/water)	3.8gal	6.5gal	7gal	See Dimensional Chart, pg. 3	
CODE STATUS	ASME U Stamp, Sec.VIII, Div. 1. Note: ASME Code jurisdiction ends at the Inlet and Outlet Elbow of each Module				
MATERIAL OF CONSTRUCTION	T-316 S/S or Carbon Steel, Investment Cast Lid & Body				
LID CLOSURE	360° Hinged Closure with Lid Handle, Safety Detents, and Lid Stop				
MAXIMUM WORKING PRESSURE	150psi or 300psi				
MAXIMUM WORKING TEMPERATURE	S/S Housings: Carbon Housings:		450°F 500°F		
MAXIMUM SUPPORT BASKET DIFFERENTIAL OPERATING PRESSURE	100psi				
INLET & OUTLET CONNECTIONS	150psi Housings: 300psi Housings:		2" Flanges, 150 lb., R/F, ANSI 2" Flanges, 300 lb., R/F, ANSI		See Dimensional Chart, pg. 3
BALL VALVES: 2" FULL PORT, T-316 S/S & TEFLON, 800psi	N/A	N/A	2	N/A	2 per Housing
FINISH	S/S Housings: Carbon Housings:				
HARDWARE	Blasted Finish, Interior, Exterior & Basket One Coat Shop Primer, Exterior				
	S/S Housings: Carbon Housings:				
PERFORATED SUPPORT BASKETS	T-316 S/S with Longitudinal Taper, 9/64" Perforations (1 per housing)				
GAUGE PORTS	1/4" NPT (2 per housing)				
VENT PORT	1/4" NPT (1 per housing)				
UPSTREAM DRAIN PORT	1/4" NPT (1 per housing)				
DOWNSTREAM DRAIN PORT	3/4" NPT (1 per housing)				
O-RINGS	Buna-N, Installed				
STAND/FRAME	S/S Housings: Carbon Housings:		S/S Adjustable Tripod Stand Carbon Steel Adjustable Tripod Stand		S/S Frame Carbon Steel Frame
LOW-PROFILE, HORIZONTAL OUTLET	Optional	Optional	Standard	Optional	Optional
SHIPPING WEIGHT (LBS)	110 lbs	130 lbs	140 lbs	See Dimensional Chart, pg. 3	

\* Flow rates are based on water in a housing without filter media. Actual flow rates are determined by the specific filter media selected, as well as the characteristics of the application.

## MODEL NUMBER CODING SYSTEM

**MATERIAL OF CONSTRUCTION**  
S = T-316 S/S, ASME Code (U-Stamp)  
C = Carbon Steel, ASME Code (U-Stamp)

**VALVED HOUSING OR SYSTEM**  
Filtration Systems Inlet & Outlet Isolation Valves, T-316 S/S  
V = Ball Valve, 3-Piece, Full-Port  
SV = Sanitary Butterfly Valve

**LOW-PROFILE, HORIZONTAL OUTLET**  
Optional on all 8" diameter filter vessels

**S - 223 - V - 300 - LP - M**

**NUMBER OF FILTER HOUSINGS**  
1 = Individual & Valved, Individual  
2-12 = Modular Systems

**HOUSING SIZE / FILTER BAG SIZE**  
2 = #2 Size (7"dia. x 33"long)  
1 = #1 Size (7"dia. x 16"long)

**INLET & OUTLET CONNECTION SIZE**  
2 = 2" Connection  
3 = 3" Connection  
4 = 4" Connection  
6 = 6" Connection  
8 = 8" Connection

R/F ANSI Flanges, NPT, or Sanitary Connections available

**300psi PRESSURE RATING**

**MODIFIED**  
Modified Equipment, as per quote or requirement

## AVAILABLE OPTIONS

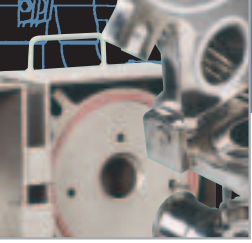

### Interior Polished Finishes:

Interior Polished Finishes for beverage, pharmaceutical, dairy, and other critical liquid process applications.



### Halal® Lining:

**HALAR** Fluoropolymer Lining offers a broad range of chemical resistance properties, a seamless filtering environment, and a safe alternative to plastic housings.



### Safety Apparatus Filter Enhancement:

**SAFesystem**® upgrade reduces employee exposure to potentially hazardous filtering processes with this unique and exclusive option.

- Modified Connections: Flanged, Threaded, or Sanitary
- Low-Profile, Horizontal Outlets
- Interior Polished Finishes, including 3A Sanitary
- **HALAR** Fluoropolymer Lining
- Epoxy Coating, interior, exterior & stand
- Mesh or Micron Lined Baskets, S/S
- Perforated Strainer Baskets, S/S
- Cartridge Chambers, S/S

- Thermal Jackets, Two-Piece, Stainless Steel
- Actuated Valves, Pneumatic or Electric
- **SAFesystem**, **Safety Apparatus Filter Enhancement**
- Alternate Outlet Locations
- Additional Ports
- Drain Valves, Vent Valves, Pressure Gauges
- Assorted O-Ring Materials

*HALAR* is a Registered Trademark of Solvay Solexis, Inc.

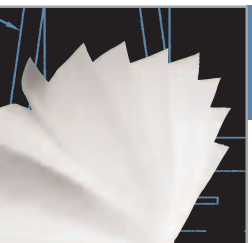

## HIGH PERFORMANCE LIQUID FILTER BAGS

*Filtration Systems* vessels and filter media are designed to work together as a system, maximizing performance and results.

- Efficiency Ratings up to 99.98%...  
*provides absolute rated performance*
- Fully Welded Construction...  
*eliminates solids bypass*
- **Zero-Bypass**® Bag Collar...  
*assures an optimum compression seal*
- **Integrated Polymeric Support**®...  
*provides superior mechanical strength*
- Ratings from 0.2 to 600 Microns...  
*absolute or nominal ratings*



**Ultrafit**® Welded and **Accufit**® Welded Liquid Filter Bags

# LOW-PROFILE, HORIZONTAL OUTLET

## LOWER WORKING HEIGHT MEANS EASIER FILTER BAG CHANGE-OUT

The Low-Profile, Horizontal Outlet is a one-piece investment casting exclusive to the *Filtration Systems* product line. This option lowers the working height of the filter vessel by 4" on Individual Housings and 3" on Multi-Housing Systems, eliminating the need for a ladder or platform when changing filter bags. As a result, ergonomic related injuries and accidental spills during change-out may be reduced.

This self-draining outlet is optional on all stainless or carbon steel Individual Housings and Multi-Housing Systems. The "LP" upgrade is available with flanged, threaded, or sanitary connections.

### LOW-PROFILE CONFIGURATION OPTIONS

#### "C" Configuration (Inlet over Outlet)

The outlet of the filter vessel is on the same plane as the inlet, or in the shape of the letter "C", in a profile view.

#### "S" Configuration (Inlet opposite Outlet)

The outlet of the filter vessel is opposite the inlet, or in the shape of the letter "S", in a profile view. In this type of configuration, the filter becomes "in-line" with existing piping.



#### Custom Outlet Configurations

The direction of the "LP" outlet, relative to the inlet, can be positioned to accommodate custom piping arrangements.

Note: In all Low-Profile configurations, the standard drain placement is opposite the outlet of the vessel. The location of the drain can be modified upon request. Please consult factory for other custom requirements.

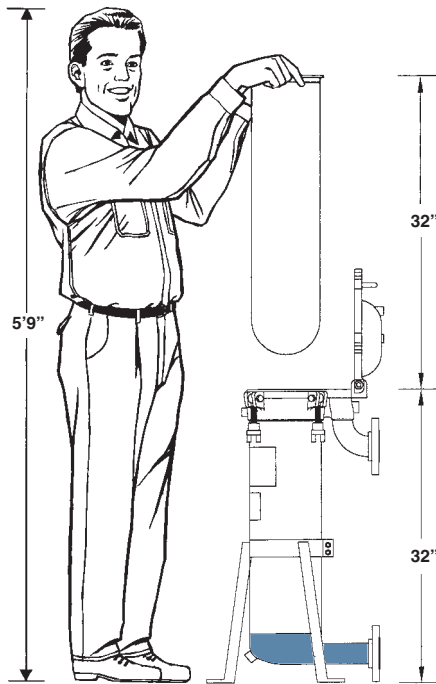
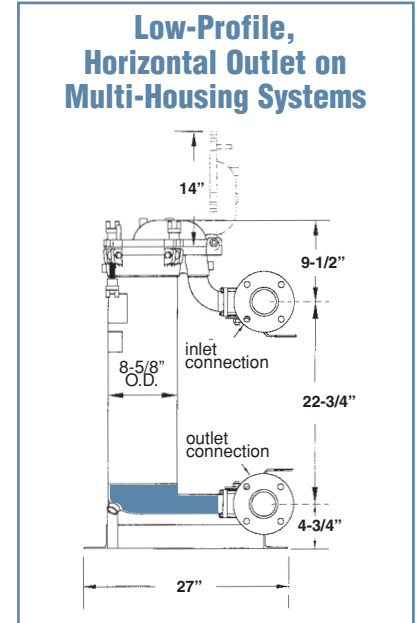

### Low-Profile, Horizontal Outlet on Individual Filter Housings

#### "C" Configuration

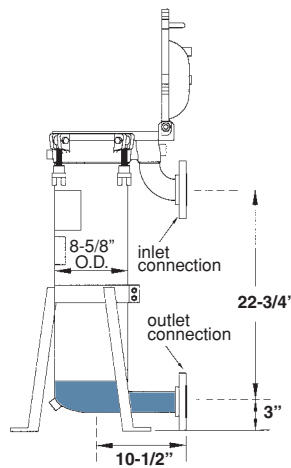

#### "S" Configuration

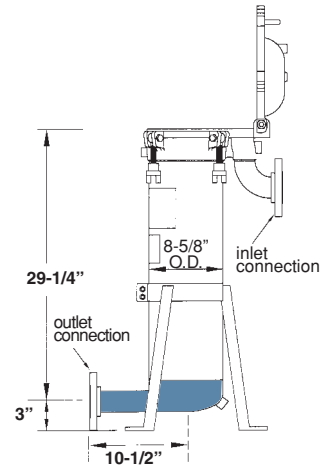

**Product Identification:** All *Filtration Systems* filter vessels have a unique serial number that can be identified by our factory. Nameplates, specifying both the serial number and maximum allowable pressure and temperature ratings, are permanently affixed to all housings.

**Product Specifications:** With over 30 years of industry expertise and proven performance, *Filtration Systems* offers quality products at responsible prices. We continually strive to improve our products through ongoing research and development; therefore, we reserve the right to change specifications without notice.

**Warranty:** *Filtration Systems* warrants our products to be free from defects in workmanship for a period of one year from the date of purchase, when used in accordance with our specific guidelines. Our only obligation and a customer's remedy, subject to our inspection and evaluation, shall be to repair or replace the product, or refund the purchase price.

**Limitation of Liability:** *Filtration Systems* shall not be held responsible or liable for any loss resulting from the resale, direct or indirect misuse, incidental or consequential damages, arising out of the use of this product.

## Filtration Systems

Division of Mechanical Mfg. Corporation  
10304 N.W. 50th Street • Sunrise, FL 33351 USA  
Tel: 954-572-2700 • Fax: 954-572-3401  
[www.filtrationsystems.com](http://www.filtrationsystems.com)

ISO 9001:2000 Certified